



4" and 6" Engine Driven Trash Pumps

- *Cast Iron or Cast Aluminum Construction*
- *Viton® /Silicon Carbide Mechanical Seals*
- *4" or 6" NPT port sizes*
- *Self-priming up to 25 ft.*
- *Engine Options: Honda or Kohler Gasoline Engine; Lombardini, Deutz or John Deere Diesel Engine*
- *Available in 13 - 57 HP Engine*
- *Some Pumps Include Heavy Duty Steel Roll Cages*
- *Two (2) Wheel Truck Assembly or Highway Trailer Standard on Some Models*
- *Solids Handling to 2-5/8" Diameter*



Model 14D1-GX390

The Gorman-Rupp line of 4" and 6" Engine Driven Trash pumps is designed for applications which require high flow efficiency and solids handling capability. Pumps are constructed of heavy duty sand cast aluminum or cast iron with replaceable ductile iron impellers and steel or cast iron wearplates. Simple front cleanout design permits easy removal of trash and debris without disconnecting hoses. Pumps are available with Honda or Kohler gasoline engines or Lombardini, John Deere or Deutz diesel engines. All are furnished with suction strainers and 90 degree discharge elbows.

*Viton® is a registered trademark of DuPont

PREMIUM HEAVY DUTY



Model 16D60-F3L

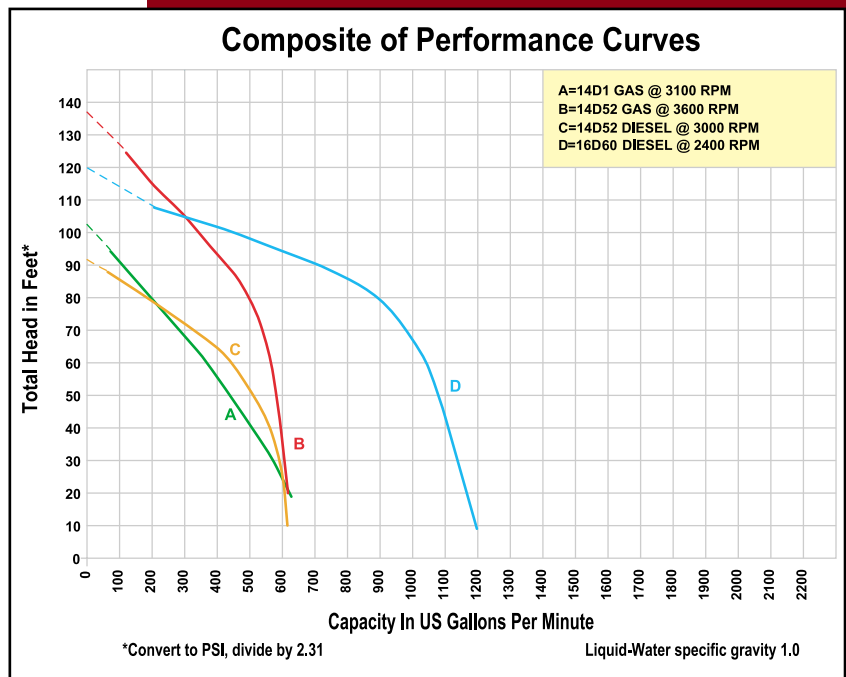

4" and 6" Engine Driven Trash Pumps

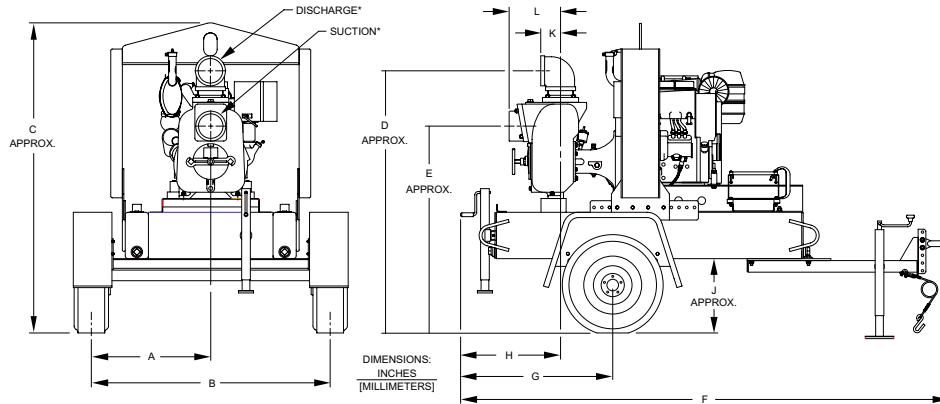

NOTE: ONLY 16D60-F3L AND 16D60-4024T SUPPLIED WITH TORSIONAL AXLE, FENDERS & LIGHT KIT

MODEL	A	B	C	D	E	F	G	H	J	K	L	SUCT*	DISCH*
14D52-12LD S/G	26.56 [674.6]	48.92 [1242.6]	47.46 [1205.5]	44.76 [1136.9]	34.14 [867.2]	78.00 [1981.2]	13.27 [337.0]	9.83 [249.7]	14.62 [371.3]	3.79 [96.3]	10.28 [261.1]	4.00	4.00
16D60-F3L	30.91 [785.1]	61.81 [1570.0]	80.26 [2038.6]	67.92 [1725.2]	53.61 [1361.7]	126.30 [3208.0]	39.37 [1000.0]	25.87 [657.1]	19.23 [488.4]	5.13 [130.3]	13.31 [338.1]	6.00	6.00
16D60-4024T	30.91 [785.1]	61.81 [1570.0]	80.26 [2038.6]	67.92 [1725.2]	53.61 [1361.7]	126.30 [3208.0]	42.12 [1060.0]	25.87 [657.1]	19.23 [488.4]	5.13 [130.3]	13.31 [338.1]	6.00	6.00

(*) STANDARD NPT PIPE THREADS.

ENGINE DRIVEN TRASH PUMPS

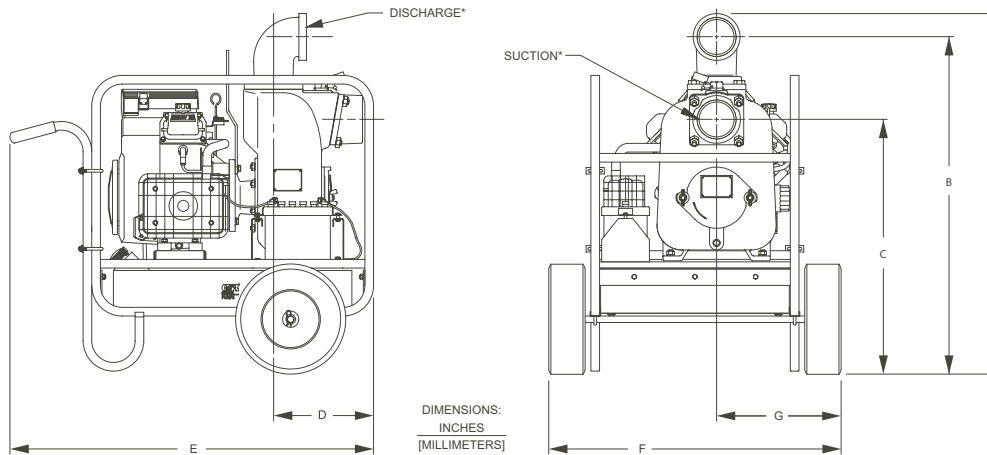

NOTE: 14D1-GX390 SHOWN WITH OPTIONAL WHEEL KIT.

MODEL	A	B	C	D	E	F	G	SUCT*	DISCH*
14D1-GX390	29.66 [753.4]	26.96 [684.8]	17.44 [443.0]	12.50 [317.5]	36.50 [927.1]	22.50 [571.5]	13.76 [349.5]	4.00	4.00
14D52-CH23 S/G	41.65 [1057.9]	38.95 [989.3]	29.38 [746.2]	11.53 [292.9]	41.94 [1065.2]	33.72 [856.6]	14.36 [364.8]	4.00	4.00

(*) STANDARD NPT PIPE THREADS.

ENGINE DRIVEN TRASH PUMPS

Model No.	Description/ Type of Pump	Ship Wt (lbs.)	Driver Type & HP	Port size Suc x dis (NPT)	Basic Construction	Seal Type & Elastomer/ Faces	Tank Size	Run time	Mounting
14D1-GX390	4" Engine Driven Trash Pumps	262	Honda 13	4" x 4"	Alum	Viton®* silicon-carbide	6.9 gal.	1.2 hrs.	Roll Cage
14D52-CH23 S/G**	4" Engine Driven Trash Pumps	509	Kohler 23	4" x 4"	Gray Iron	Viton®* silicon-carbide	10 gal.	5 hrs.	Wheels
14D52-12LD S/G**	4" Engine Driven Trash Pumps	775	Lombardini Diesel 18.1	4" x 4"	Gray Iron	Viton®* silicon-carbide	11 gal.	15.3 hrs.	Wheels
16D60-F3L**	6" Engine Driven Trash Pumps	2670	Deutz Diesel 55 (air cooled)	6" x 6"	Gray Iron	Viton®* silicon-carbide	61 gal.	31 hrs.	Wheels
16D60-4024T**	6" Engine Driven Trash Pumps	2670	John Deere Diesel 57 (water cooled)	6" x 6"	Gray Iron	Viton®* silicon-carbide	61 gal.	31 hrs.	Wheels

*Viton® is a registered trademark of DuPont **12 volt electric start. Battery not included

Standard Features

- ▶ Suction Strainer and 90° Discharge Elbow
- ▶ Self-priming to 25' with Built-in Flap Valve
- ▶ Replaceable Ductile Iron Impeller and Cast Iron or Steel Wearplate
- ▶ Maximum Temperature to 160°F
- ▶ Maximum Operating Pressure to 100 PSI
- ▶ Engine Options: Honda or Kohler Gasoline Engine; Lombardini, Deutz or John Deere Diesel Engine

WARNING: Do not use in explosive atmosphere or for pumping volatile flammable liquids.

See price book page 7

The Gorman-Rupp Company reserves the right to discontinue any model or change specifications at any time without incurring any obligation.

CP21-22 / 1006